

THE INFORMATION CONTAINED IN THIS DRAWING IS THE SOLE PROPERTY OF BUD INDUSTRIES INC. ANY REPRODUCTION IN PART OR WHOLE WITHOUT THE WRITTEN PERMISSION OF BUD INDUSTRIES INC. IS PROHIBITED.

DWG. NO.	HH-3570
ISSUE	REVISIONS
(A)	CHG'D MAT'L CALL-OUT 10-29-08 DAB
(B)	PER ECN #10509 7-9-09 DAB

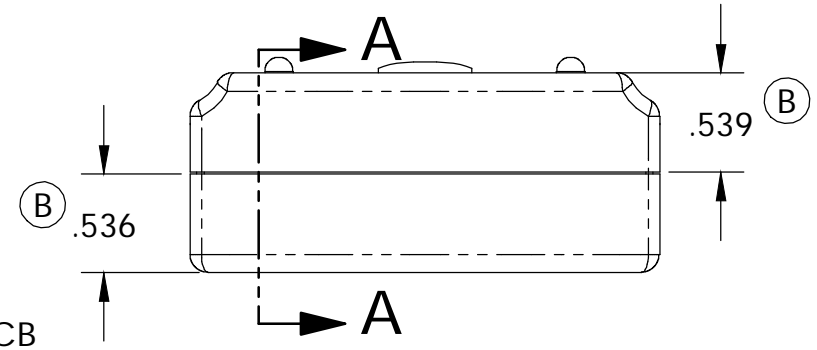
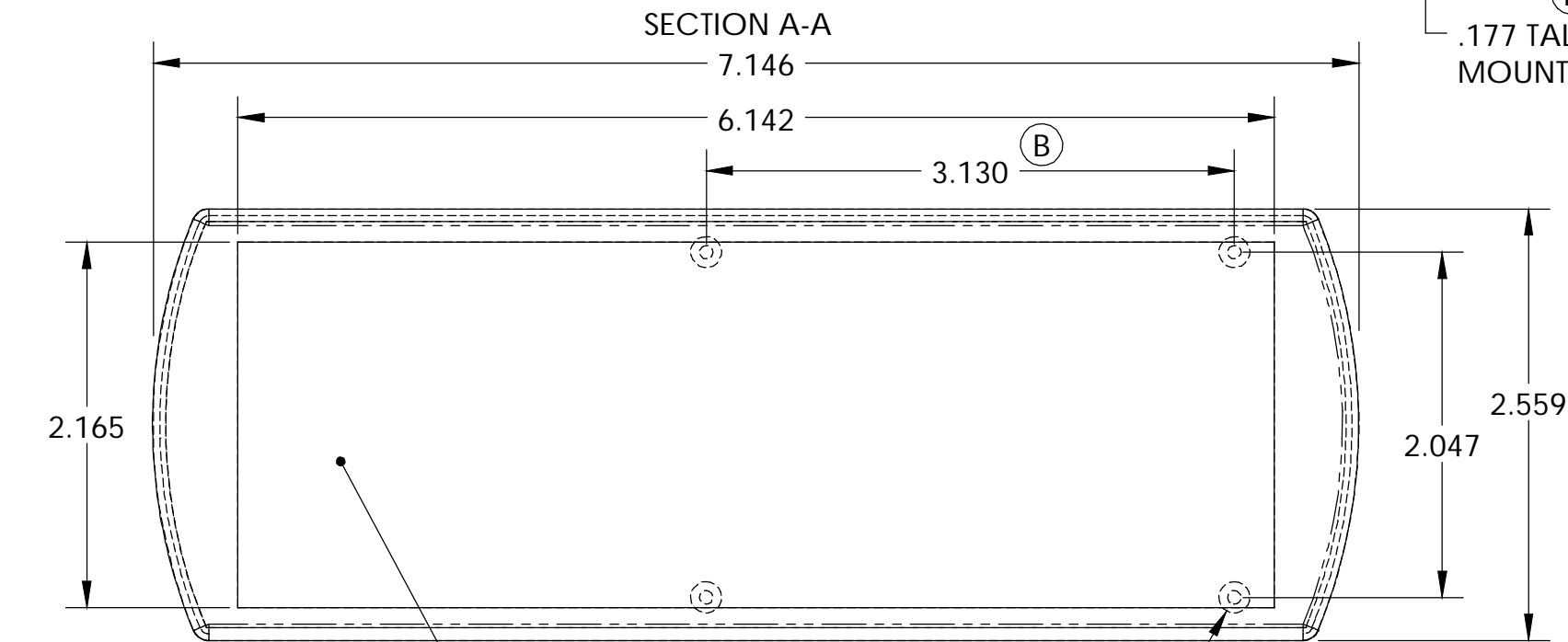
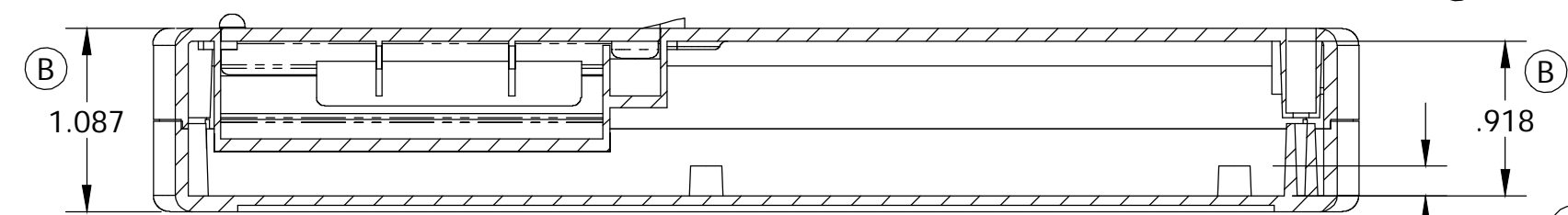
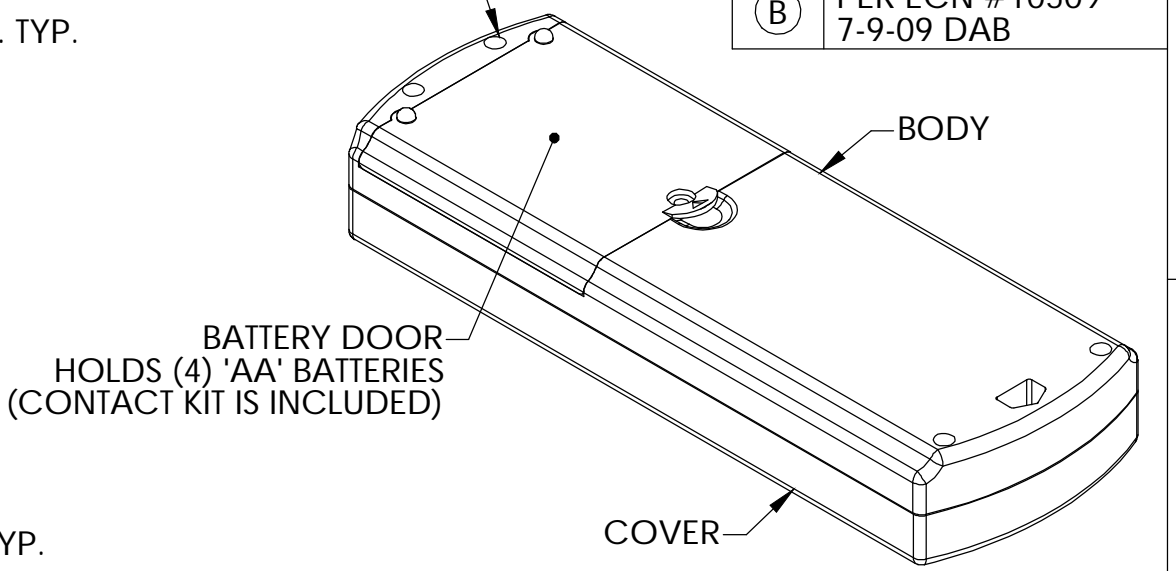
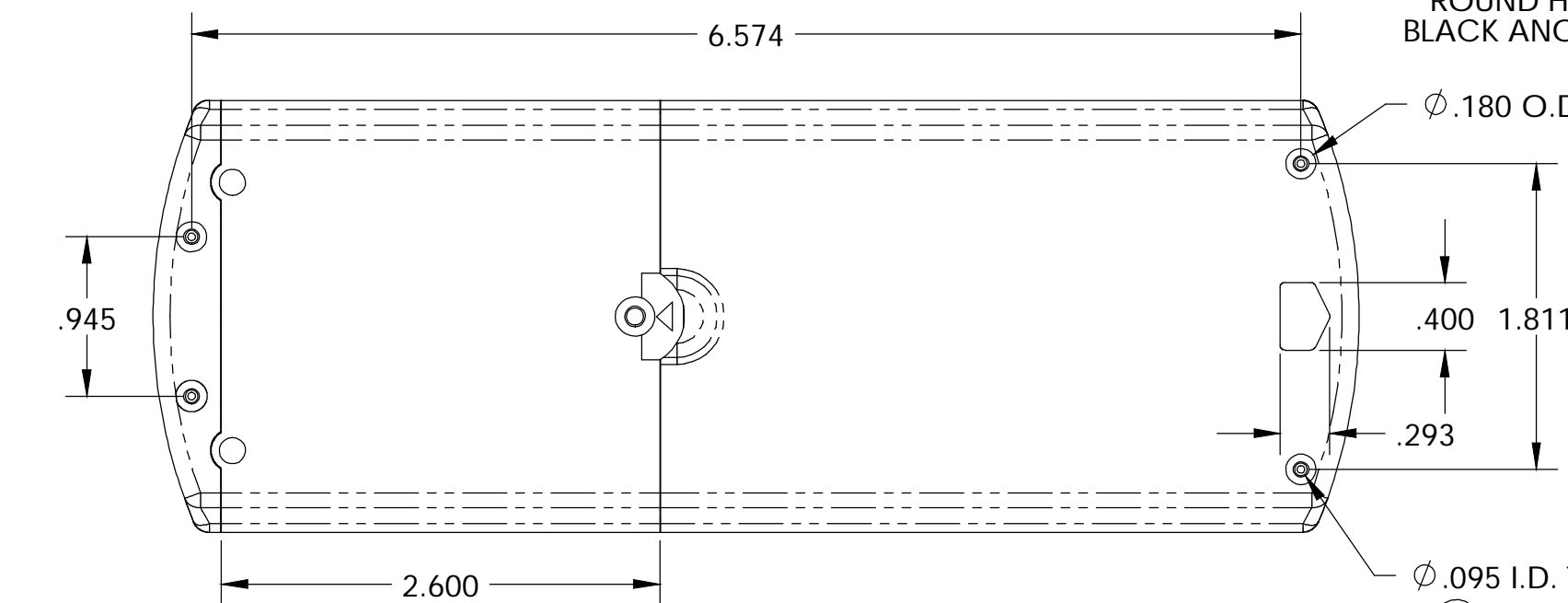

MATERIAL: ABS - UL94-HB (A)
 FINISH: LIGHT TEXTURE
 COLOR: BLACK (HH-3570-B) OR LIGHT GRAY (HH-3570-G)
 PACKAGING: SHRINK WRAP WITH A SELF-ADHESIVE LABEL AFFIXED ON THE OUTSIDE.
 MAXIMUM PC BOARD SIZE: 3.50 x 2.312 (WITH MAX. 0.62 COMPONENT HEIGHT)

TOLERANCES: +/- .005 BETWEEN HOLE CENTERS +/- .015 FROM SHEARED EDGE +/- .032 FROM A BENT SURFACE +/- .062 BETWEEN ASSEMBLED SURFACES UNLESS OTHERWISE SPECIFIED	CAD GENERATED DRAWING, DO NOT MANUALLY UPDATE	
	APPROVALS	DATE
	DRAWN DP	6/10/05
	CHECKED	
MATERIAL AS NOTED	APPROVED	
FINISH AS NOTED		
DO NOT SCALE DRAWING		

BUD INDUSTRIES INC.	
GRABBER STYLE J	
SIZE B	DWG. NO. HH-3570
SCALE	CAD FILE: SHEET 1 OF 1

QTY.	USED ON