

PART
NAME

STEEL INTERNAL PANEL

PART
No.

NBX-32912

REV.
DATE

7/8/22

DRAWING FOR REFERENCE

WE RESERVE THE RIGHT TO MAKE CHANGES TO OUR
STANDARD PRODUCTS. PLEASE CONSULT WITH BUD INDUSTRIES
PRIOR TO USING THIS DRAWING FOR DESIGN PURPOSE.

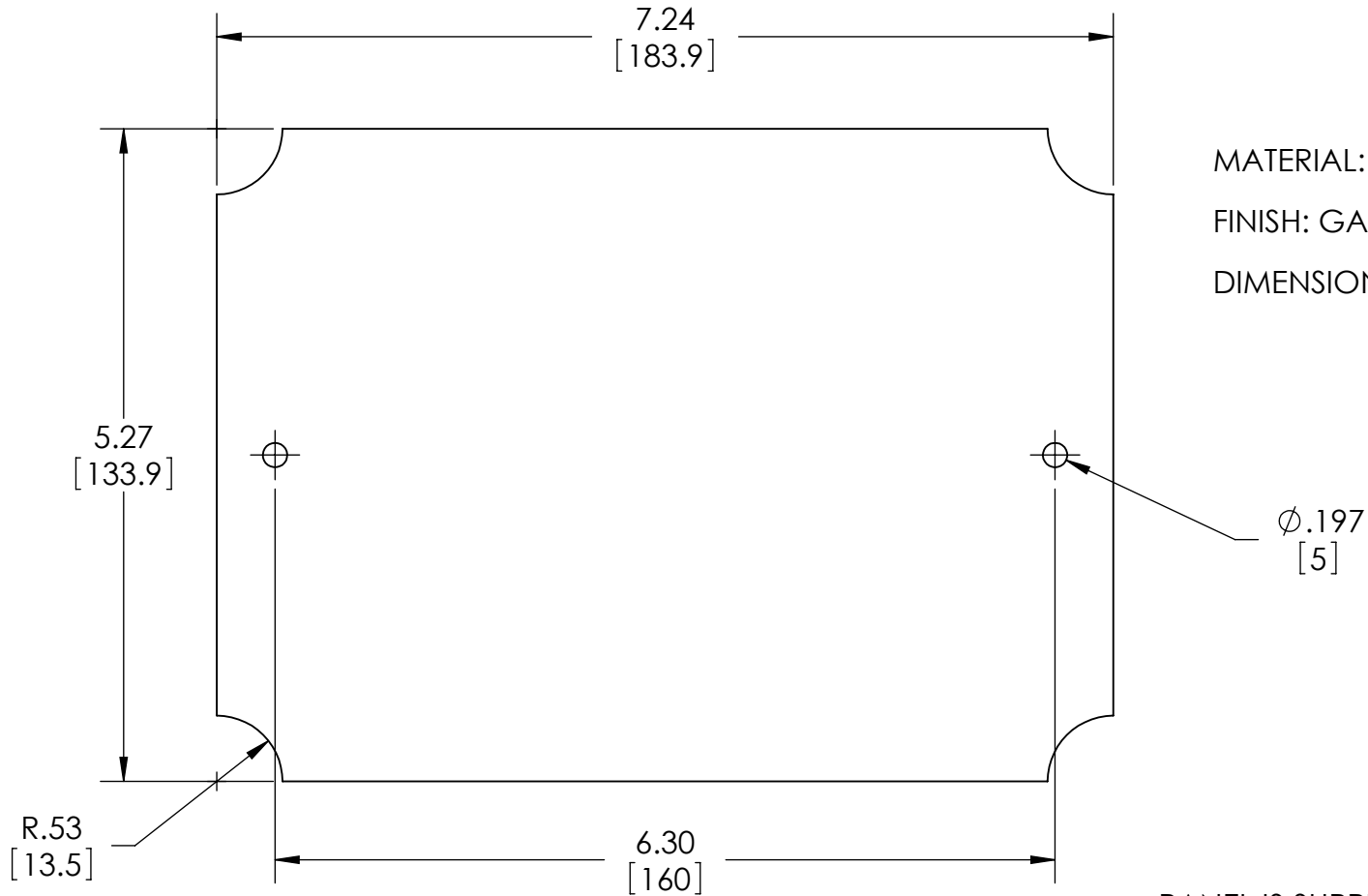

MATERIAL: 16 GA. [1.5mm] STEEL

FINISH: GALVANIZED

DIMENSIONS ARE IN INCH [MILLIMETER]

PANEL IS SUPPLIED WITH QTY. (2)
M4X0.7 x 8mm LG. TRUSS HD. PHILLIPS
DRIVE STAINLESS STEEL MACHINE
SCREWS

WILL FIT ENCLOSURES:
NBF-32012, NBF-32112, NBF-32212,
NBF-32312, NBF-32412