



PART NAME

NEMA 4X PLASTIC BOX (PTS SERIES)

PART No.

PTS-25338 & PTS-25338-C

REVISION DATE 01/04/22

DRAWING FOR REFERENCE

WE RESERVE THE RIGHT TO MAKE CHANGES TO OUR STANDARD PRODUCTS. PLEASE CONSULT WITH BUD INDUSTRIES PRIOR TO USING THIS DRAWING FOR DESIGN PURPOSE.

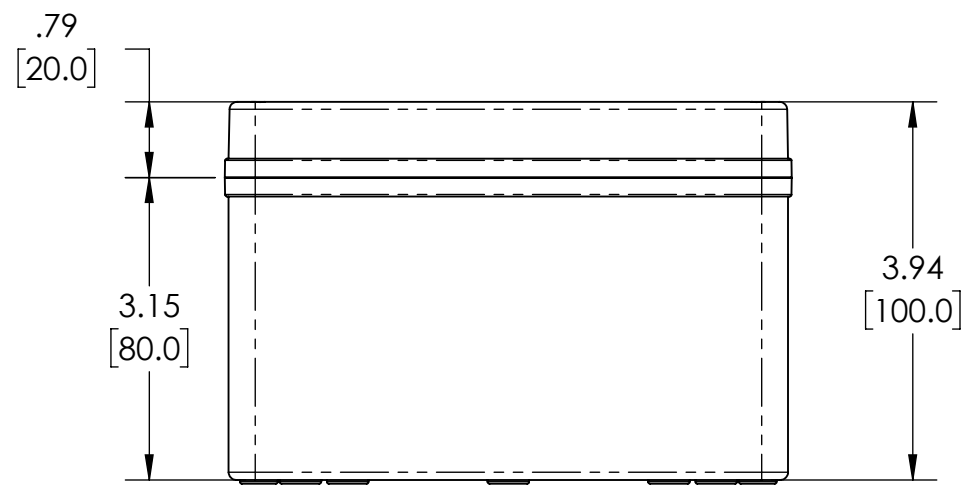
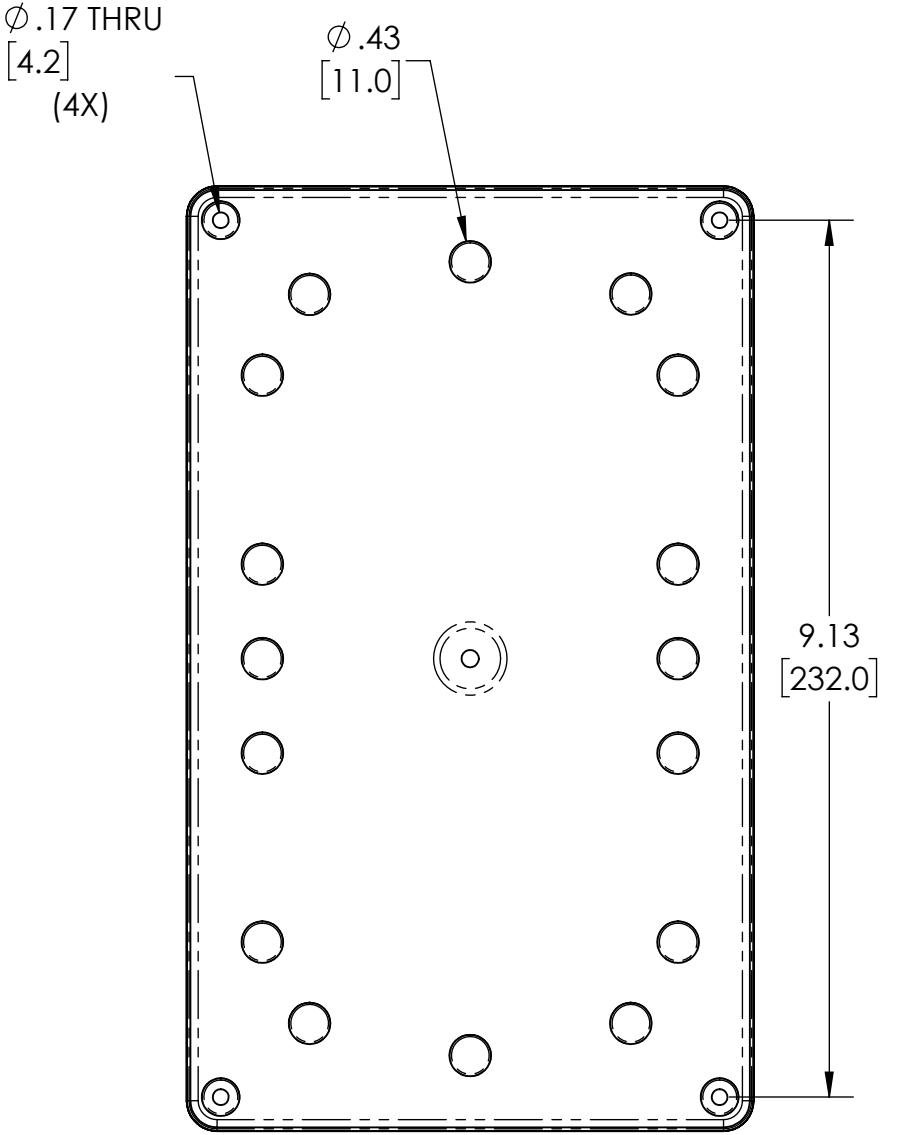
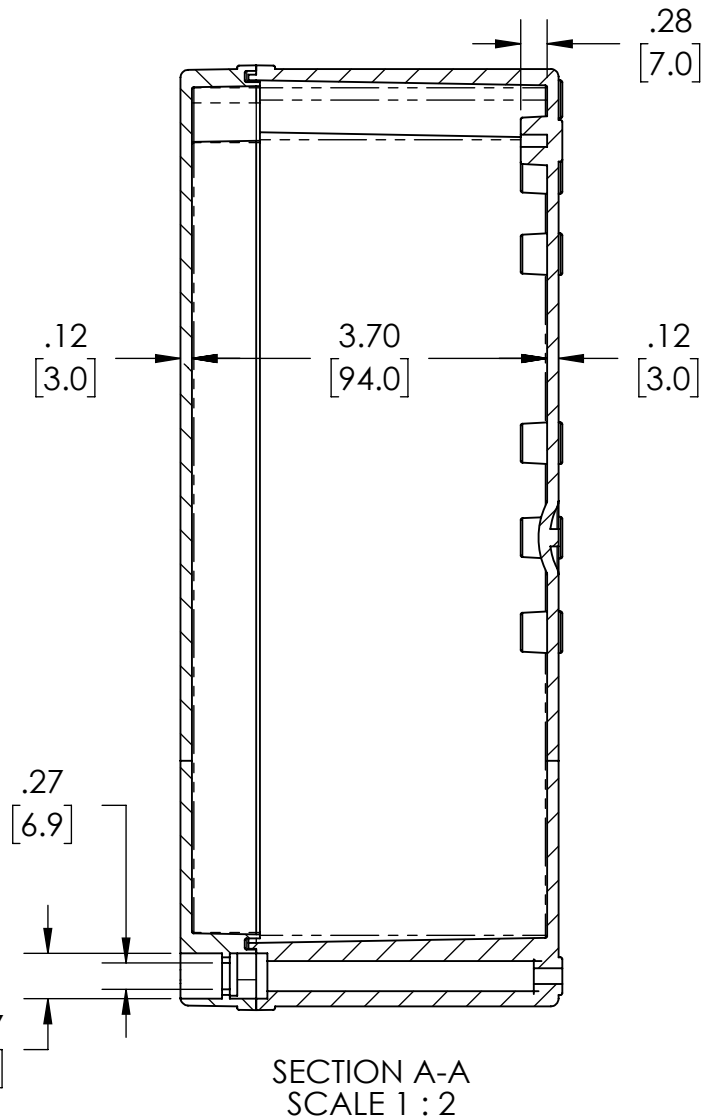
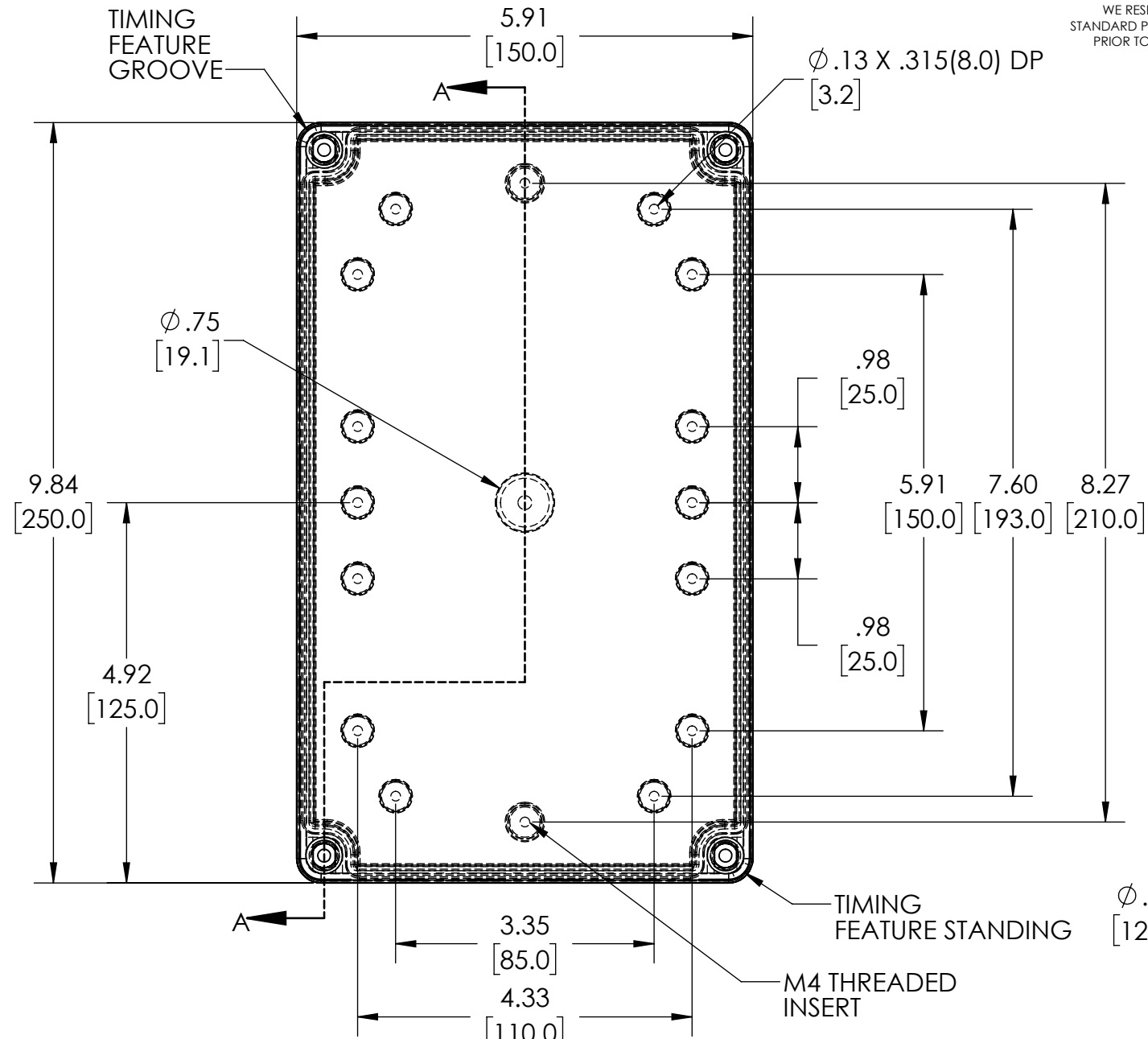

- NOTES:
- 1- MATERIAL: BODY - POLYCARBONATE WITH 10% FIBERGLASS COVER - POLYCARBONATE
 - 2- COLOR: NO SUFFIX - GRAY BODY & GRAY COVER (-C) SUFFIX - GRAY BODY & CLEAR COVER
 - 3- CONTINUOUS Poured FOAM GASKET IN COVER
 - 4- COVER ATTACHES WITH NON-METALLIC CAPTIVE SCREWS (ITEMS NOT SHOWN)
 - 5- SUPPLIED WITH TWO M4 x 8mm LG. PAN HEAD SCREWS (ITEMS NOT SHOWN)
 - 6- DIMENSIONS ARE INCH [MM]

- OPTIONAL ACCESSORIES:
- STEEL INTERNAL PANEL #PTX-25328
 - PLASTIC INTERNAL PANEL #PTX-25328-P
 - STEEL EXTERNAL BRACKET #NBX-10922
 - PLASTIC EXTERNAL BRACKET #PIX-4117

